

6M26

PowerKit COP Diesel Engine

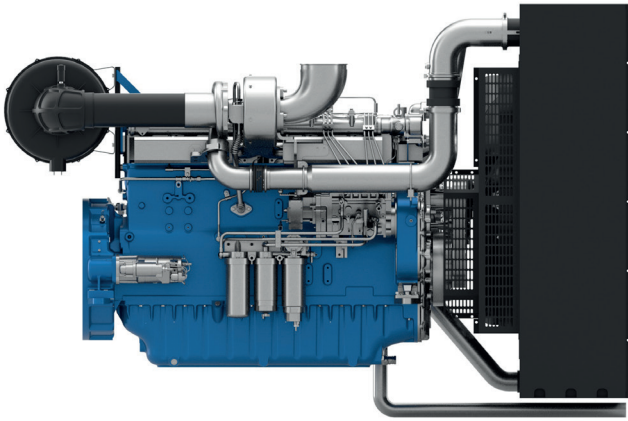

Bore & Stroke (mm)	150 x 150
Displacement (L)	15.9
N° of Cylinders	6
Cylinders Arrangement	In line
Fuel System	Mechanical
Governor (Gov.)	Electronic
Aspiration (Asp.)	Turbocharged & air-to-air cooled

Customer benefits

Warranty terms – 2 yrs unlimited PRP, 4 yrs/800h ESP
 50°C Cooling package standard with low derating
 Low fuel consumption across the range
 Extended mean time between overhauls (MTBO)

COP									
COP Diesel Engine Models	Gross Engine Output		Typical Generator Output				RPM	Asp.	Gov.
	COP	PRP	COP		PRP				
			kWm	kWe	kVA	kWe			
6M26G2D0/5	370	448	320	400	400	500	1500	T/A-A	ELEC
6M26G2D0/6	409	506	360	450	450.4	563	1800	T/A-A	ELEC

Standard Equipment

Engine and block	Cast iron cylinder block with inspection door per cylinder Cast iron cylinder liners, wet type and replaceable valves guides and seats Separate cast iron cylinder heads with 4 valves Hardened steel forged crankshaft with induction hardened journals, crank pins and radius Lube oil cooled light alloy pistons with high performance piston rings
Cooling System	Radiator and hoses supplied separately Thermostatically-controlled system with belt driven coolant pump and pusher fan
Lubrication system	Full flow screw able oil filters Lube oil purifier with replaceable cartridge Water cooled lube oil cooler
Fuel system	In line fuel injection pump with flanged electronic governors Duplex fine filter and water separation filter assembly with transparent cup for better efficiency Electric fuel priming pump integrated in the filters support
Air intake and exhaust system	Top mounted turbocharger optimized for gen-set application Special rear mounted air filter with restriction indicator Exhaust manifold and turbocharger shield for heat isolating
Electrical System	24 Vdc electric starter motor and battery charging alternator LOP + HWT sensors
Flywheel and housing	SAE 1 flywheel housing and 14" flywheel

Dimensions and dry weight (mm/kg)

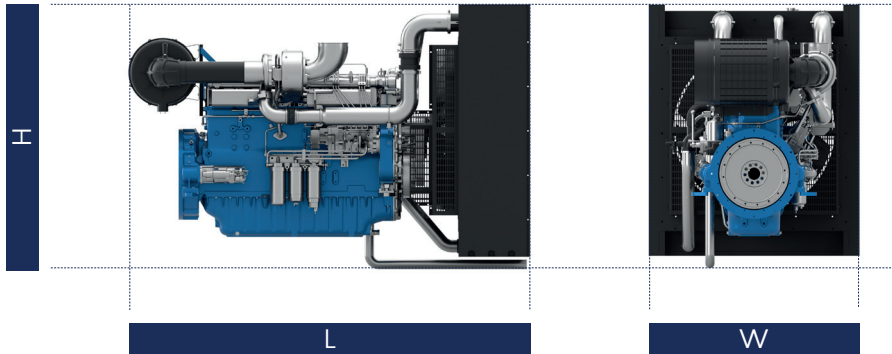

Diesel Engine	Speed RPM	Dimensions and dry weights including radiator			
		L mm	W mm	H mm	Weight kg
6M26G2D0/5	1500	2808	1500	1764	2300
6M26G2D0/6	1800	2808	1500	1764	2300

Ratings definitions

Continuous Power (COP)

Continuous Power is the maximum power available for an unlimited period of use at a constant load factor. No overload capability is allowed.

- 1) All ratings are based on operating conditions under ISO 8528-1, ISO 3046, DIN6271. Performance tolerance of ±5%.
- 2) Test conditions: 100 kPa, 25°C air inlet temperature, relative humidity of 30%, with fuel density 0.84 kg/L. Derating may be required for conditions outside these; please contact the factory for details.

